

SMS Series

HEAVY DUTY, FLEXIBLE DESIGN

- Heavy-duty knife granulator for tough applications and maximum outputs
- Flexible design for multiple applications by means of a removable deflection wedge
- Energy-efficient double cross cutting action
- Constant cutting circle due to adjustable rotor and bed knives
- Optimum access to the cutting chamber for ease of cleaning and maintenance





Knife adjustment fixture

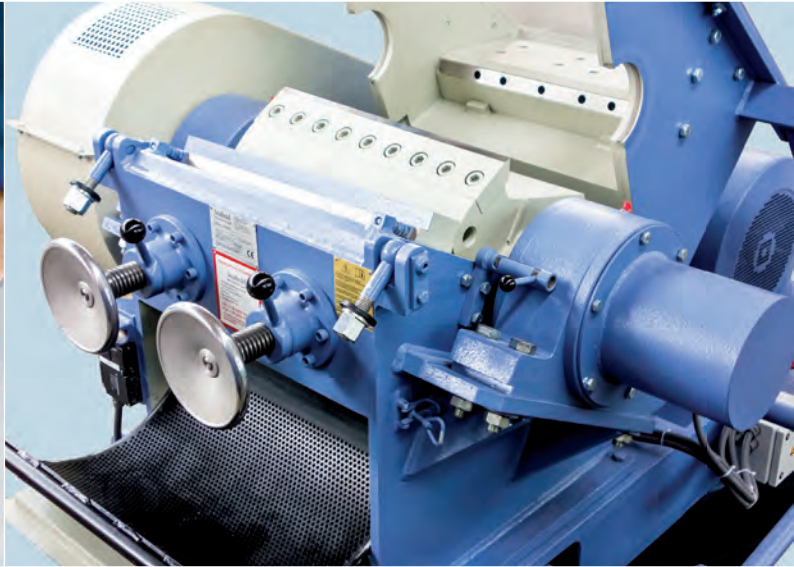

Fully accessible cutting chamber and drop down screen cradle

The SMS series has the same innovative advantages of all the Herbold granulators:

- Heavy duty welded/machined steel construction
- Split housing design above the rotor for maximum access
- Outboard mounted pillow block bearings
- Rotor and bed knives are adjusted from outside of the granulator
- Constant cutting circle due to adjustable knives
- Compact and space-saving design

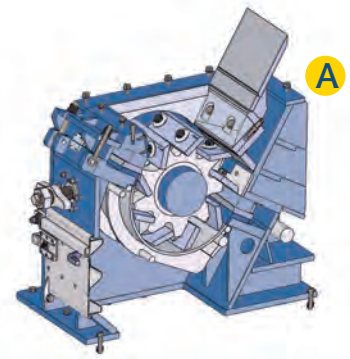

*Cross section of cutting chamber with deflection wedge **A** for massive pieces*

The SMS series is designed for wide application range

- The deflection wedge is an insert with a 3rd bed knife extending the range of applications. With deflection wedge removed the feed opening is wider and allows size reduction of large bulky parts or drums. With the deflection wedge installed thick-walled pipes, thick sheets and other large component parts can be processed.

Knife adjustment from outside of the granulator

- The rotor and bed knives are pre-adjusted in a fixture outside of the granulator. This process reduces downtime as the granulator is still in operation while the knife sets are being readied and as both sets of knives are adjustable to ensure that the distance from the cutting edge of the knife to the screen is always the same.

Optimum access for easy cleaning and maintenance

- For cleaning and maintenance purposes the granulator can be opened very quickly. The housing is a hinged two-piece split design, the upper section hinges backwards for access. This design provides optimum access to the cutting chamber. The screen is removed through the maintenance door in the front of the cutting chamber providing easy and quick cleaning (e. g. color or product changes) a standard feature of the Herbold granulators.



SMS 80/160 SB

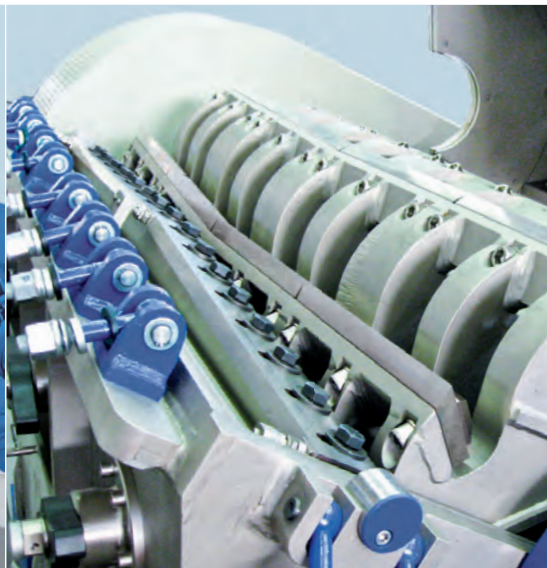

Double cross cutting by chevron-shaped knife arrangement of rotor and stator knives



Herbold rotor series G

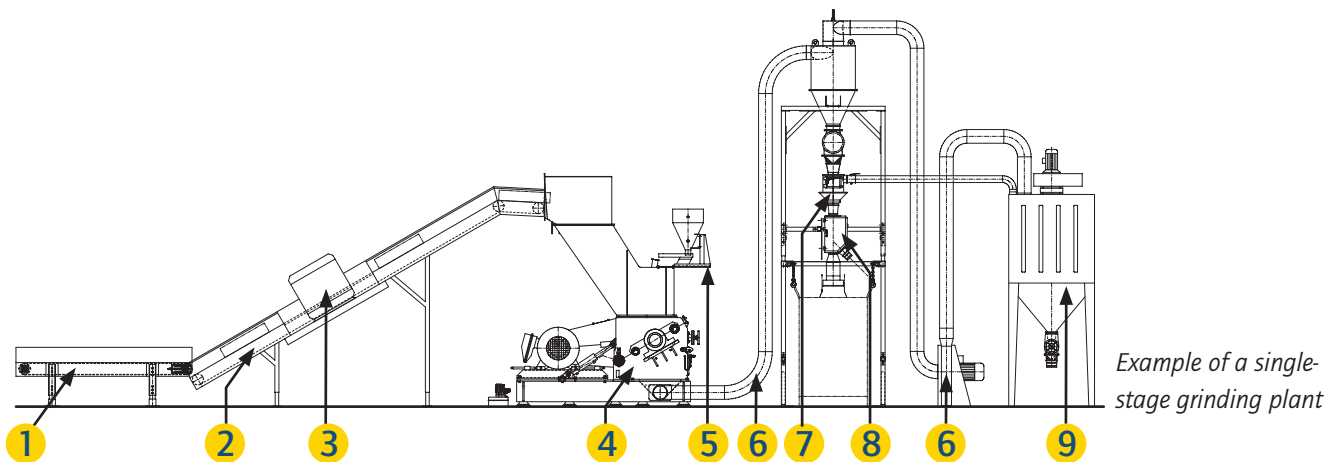

- 1 Storage conveyor horizontal belt
- 2 Inclined conveyor belt
- 3 Metal detector ferrous/non ferrous
- 4 Granulator with guillotine style rotor
- 5 Dosing of separating agent
- 6 Negative pressure pneumatic conveying system
- 7 Fines separator model HS to separate and recover the separating agent
- 8 Metal separator
- 9 Extract air filter/dust collector

Double cross cutting action with outboard mounted rotor bearings

- The rotor and bed knives are mounted in opposing angles to ensure a steady cutting gap across the full length of the knife. Thus, the power requirement is reduced, the inertia is increased, and the quality of the regrind is improved – less fines and increased bulk density. The rotor bearings of all Herbold granulators are mounted outside of the cutting chamber using steel pillow block housings not cast.
- Starting from a rotor width of 1000 mm and up you also can opt for the double cross cutting design with the chevron-shaped cutting geometry. The chevron design reduces wear at the side walls of the cutting chamber and the plastification of heat-sensitive materials.

A key design feature of the Herbold granulator is that the bed knives are mounted at an inclined position ensuring a constant knife gap across the full working width of the knives. This sets us apart from our competitors who use axially parallel mounted bed knives design.

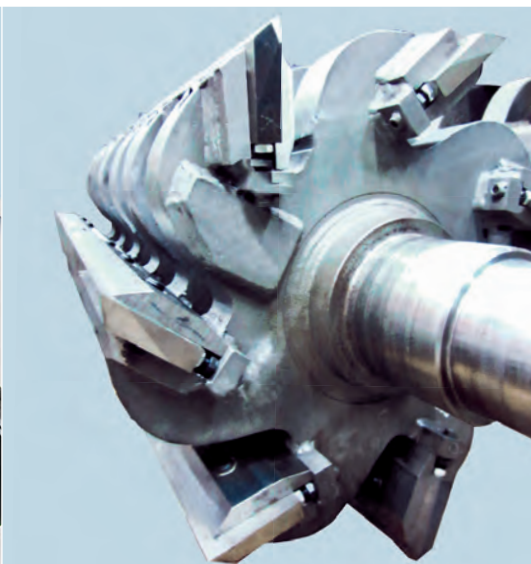

Herbold rotor series H



Herbold rotor series A

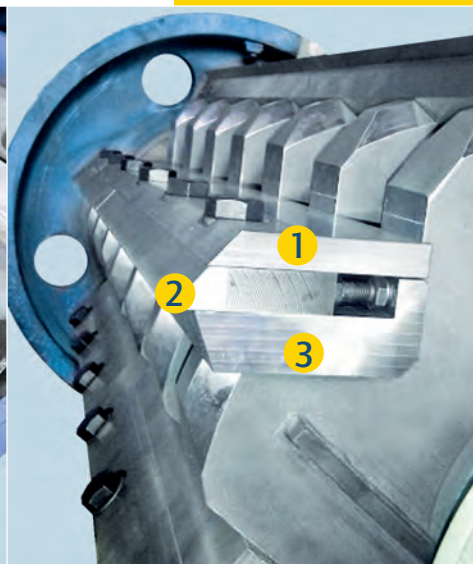

Herbold rotor series F

- 1 Support plate for knives
- 2 Rotor knife
- 3 Replaceable wear part

Wear protection for abrasive materials

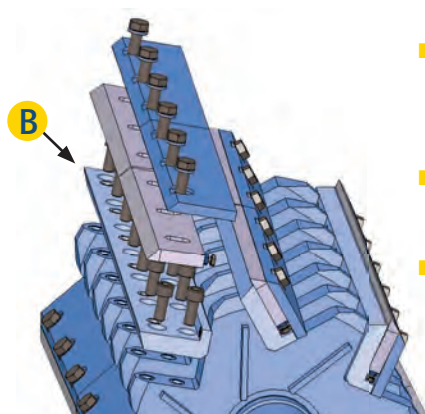

- For the processing of abrasive materials (e. g. glass-fiber reinforced plastics) the Herbold series SMS features an optional complete wear protection package for the granulator's housing and rotor.
- All areas susceptible to wear can be fitted with bolted exchangeable wear parts throughout the cutting chamber.
- The susceptible areas of rotors are manufactured as replaceable wear part **B** instead of plating/hard facing that in a time need cost-intensive repair.

Sound insulation

- With the overall ambient noise of operating plants on the rise sound insulation gains more and more importance. According to the application Herbold offers different sound insulation concepts: e. g. 2-piece sound insulation boxes, sound insulation cabins, sound insulation tunnels for conveyor feed applications, sound insulation for pneumatic conveyors. With the customers design requirement Herbold's design team can provide a suitable solution to meet those needs.

EHST knife series

- For customers with demanding or abrasive applications where knife edge life is short Herbold Meckesheim has designed the new EHST knife series. During testing and continuous operation at customer's facilities in most cases we were able to double service life and in certain applications it was even tripled. Provide us your application and ask us how these EHST series knives could help you reduce your operating costs as the price to performance ratio is impressive.



Sound insulation cabin with sound insulation tunnel, conveyor belt and metal detector

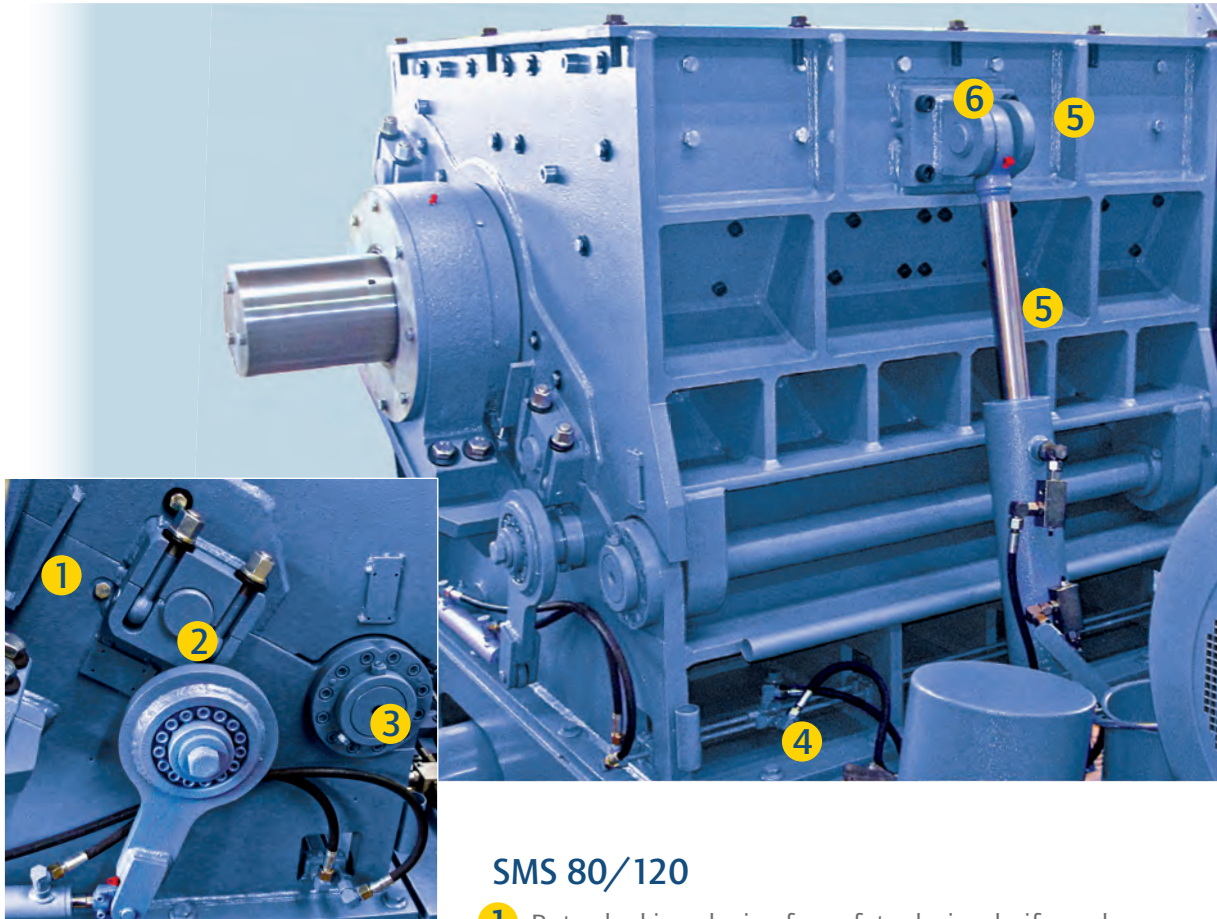

SMS 80/120

- 1 Rotor locking device for safety during knife exchange
- 2 Additional lateral fasteners for additional clamping force
- 3 Heavier shaft connection between upper and lower section
- 4 Bottom flange with backward extension
- 5 Additional reinforcements at the rear wall of the housing
- 6 New position of the pivoting cylinder

The highlighted models are manufactured as standard units and are available at short notice. All other types are made to order. Intermediate sizes can be supplied after agreement.

Range of the SMS series

Type	Feed opening ¹ mm	Rotor Ø mm	Weight ² kg	Capacity ³ kg/h	Drive kW
SMS 30/50	500 x 490	300	1800	200-400	11-37
SMS 30/80	500 x 790	300	2100	250-500	11-37
SMS 45/60	600 x 578	450	3000	400-1200	37-90
SMS 45/100	600 x 980	450	4800	600-1500	45-90
SMS 60/100	720 x 980	600	5000	1000-2200	55-110
SMS 80/120	940 x 1154	800	9000	2000-5000	75-160
SMS 80/160	940 x 1555	800	11000	2500-6000	90-200
SMS 80/200	940 x 1960	800	15000	3000-8000	90-200

¹ Flange section on the upper part of the housing

² Standard model

³ Dependent on the screen hole size and feed material



Our product range

Guillotines
Shredders
Hammer mills
Granulators
Pulverizing systems
Washing systems & components
Plastcompactors/agglomerators

Options/specialized features

Herbold granulators can be incorporated into any automated production line or process as we have a large number of options available as well as a design team to meet your needs. Options include but not limited to the following:

- Electronic metal separation and magnetic units for extraction of foreign metallic objects
- Air extractors and screening machines for separation of dust particles and specific light parts on the granulate
- Amperage overload cut-out for regulating the load and amount of feed articles during the loading of the machine
- Pneumatic and mechanical loading units for feeding the machine or for removal of the finished granulate
- Pre-crushing unit for reduction of heavy-duty materials and to regulate a continuous flow of material
- Pulverizers for fine particle size
- Storage silos before and after the granulator
- Conveyor belts and feed rolls for sheeting, edge trims and webbing



For more information, please see our videos on our website www.herbold.com

Herbold Meckesheim GmbH
Industriestr. 33 | 74909 Meckesheim | Postfach 1218 | 74908 Meckesheim | Deutschland
Tel.: + 49 (0) 6226/932-0 | Fax: + 49 (0) 6226/932-495
E-Mail: herbold@herbold.com | Internet: www.herbold.com

Subsidiary in the US: Herbold Meckesheim USA | Resource Recycling Systems Inc.
130 Industrial Drive | North Smithfield, RI 02896, USA | P.O. Box 239 | Slatersville, RI 02876, USA
Tel.: + 1 401 597/5500 | Toll-free (US/CDN): +1 888/612 RRSI (7774) | Fax: + 1 401 597/5535
E-Mail: info@herboldusa.com | Internet: www.herboldusa.com

All indications are not binding and subject to change. 04/2019

HERbold
MECKESHEIM

