

Heavy Material Separator in wet execution of the SAS

The new heavy material separator of the SAS series with a screw as basis presents a well-priced alternative to the SA series. This new development is used if only heavy materials have to be separated in order to protect downstream units.

The SAS series can optionally be optimised with an upward water flow in the discharge area in order to minimise the loss.

Ø screw conveyor:	ca. 500 mm
Overall length:	ca. 4300 mm
Overall width:	ca. 1600 mm
Overall height:	ca. 3700 mm
Drive:	ca. 2,2 kW

Functioning:

Infeed of the material into the feed hopper of the heavy material separator underneath of which is placed an inclined screw conveyor evacuating the good material from a chamber filled with water.

In the front area of the heavy material separator, the heavy materials are separated from the good material. By injecting water into the chamber an upward water flow is created for the good material, sedimenting heavy materials (stones, metals, glass, etc.) are evacuated from the heavy material separator via a double-valve combination worked at regular intervals and discharged into a container provided by the customer.

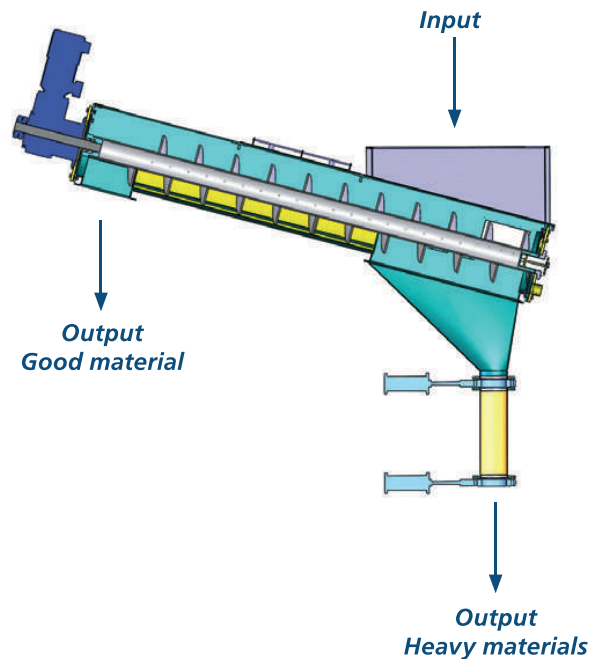

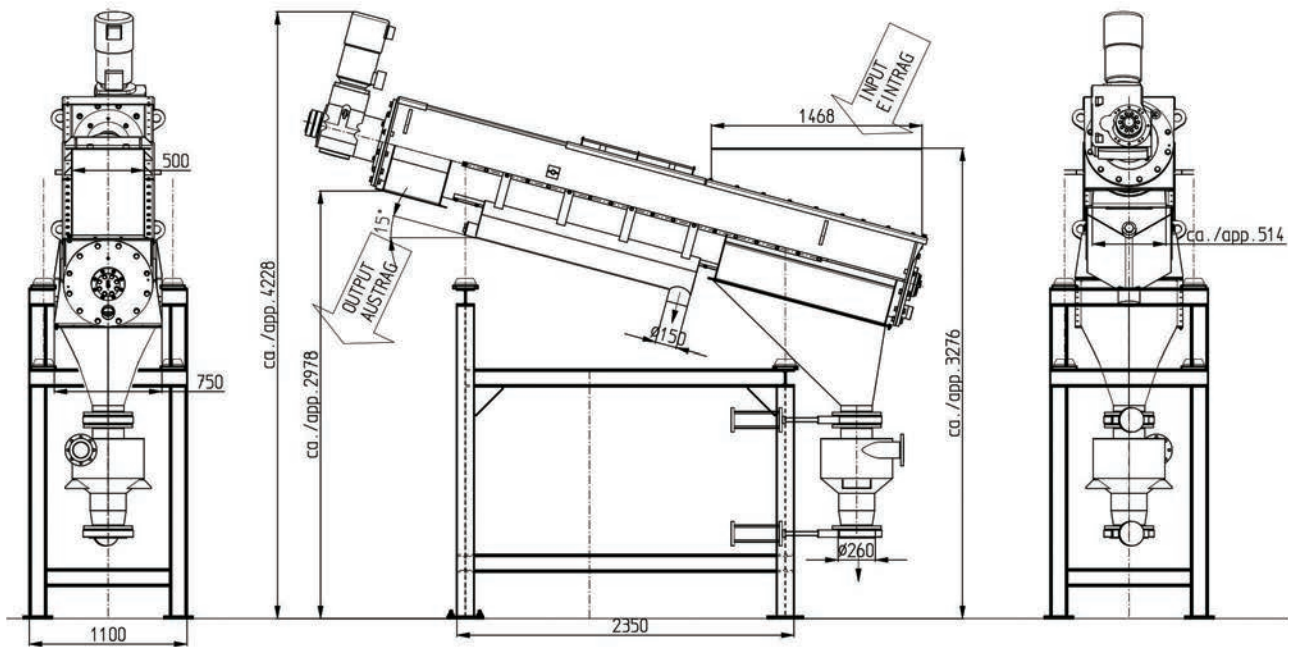

According to the feeding material and the required capacity/h several sizes are available.

Technical data:			
Type	Number of screws	Capacity with shredded film*	Capacity with rigid plastics*
SAS 50/430	1	up to 1.000 kg/h	up to 2.000 kg/h
SAS-2 50/430	2	up to 2.000 kg/h	up to 4.000 kg/h

* Depending on grain size and material type.

For any further information also see Information Sheet 51 Heavy Material Separator and Information Sheet 58 HERBOLD Pre-washing Unit.

Our Product Range

Size Reduction

- Shredder
- Granulators
- Pulverizing Systems

Washing / Separation Systems & Components

- Pre-washing Units
- Friction Washers
- Separation Tanks and Hydrocyclones
- Mechanical and Thermal Drying
- Water Processing

Agglomeration

- Plastcompactors

Service

- Parts and Overhauls
- Inspections and Trouble Shooting
- Upgrades and Performance Service

HERBOLD Meckesheim GmbH

Industriestr. 33 • 74909 Meckesheim • Fon: + 49 (0) 6226 / 932-0 • Mail: HERBOLD@HERBOLD.com • Web: www.HERBOLD.com

Specifications are not binding and subject to change without notice. 10 / 2019